

General specifications

Description	Cylindrical Li-ion NCA Rechargeable cell
Model	UNCA18650-35HP
Rated Capacity	3350 mAh
Min. Capacity	3250 mAh
Platform Voltage	3.60 V
Standard Charging	CC-CV, Std.0.2C ₅ , 4.2 V, Note: C ₅ , nominal capacity cut-off at 1/50C ₅ , 8.0 h 25 °C ± 2°C 0.2 C ₅
Charging current (max.)	0–10 °C: 0.2C ₅ 10–45 °C: 0.5C ₅
Standard Discharging	CC, 0.2C ₅ (cut-off at 2.5 V)
Discharging current (max.)	10 A (25 °C)
AC Impedance (AC 1 kHz)	≤ 25 mΩ
Cycle life	500 th cycle > 70% of 1 st cycle capacity

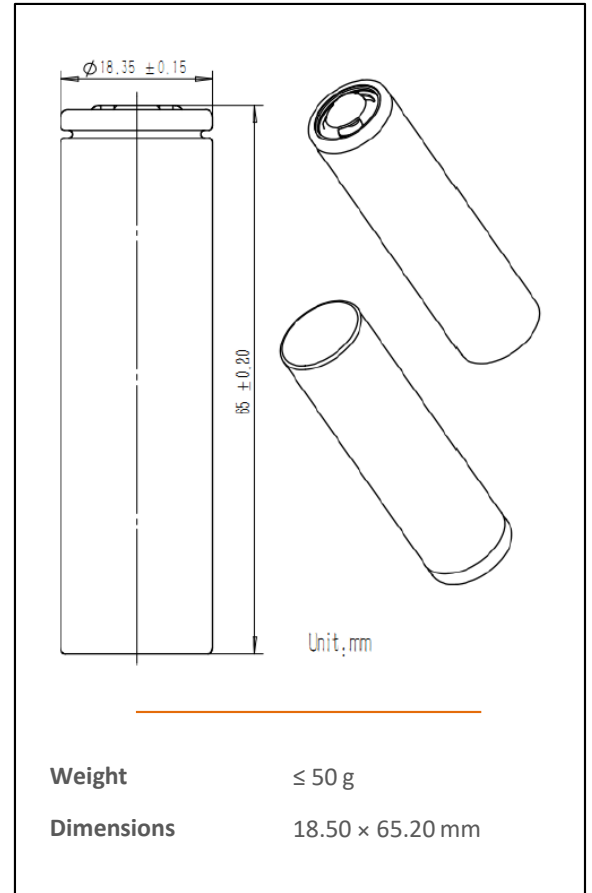

Discharge characteristics (by rate of discharge)	0.2 C ₅ = 100% 0.5 C ₅ ≥ 96% Cells are to be charged per standard charge profile. The discharge capacity of each cell at respective discharge rate shall be compared with the discharge capacity at 0.2C ₅ .
	1.0 C ₅ ≥ 95% 2.0 C ₅ ≥ 93% 3.0 C ₅ ≥ 90%
Discharge characteristics (by temp.)	60 °C ≥ 100% 45 °C ≥ 100% Discharge: CC 0.2C ₅ , 2.5 V cut-off at each temperature
	25 °C = 100% 0 °C ≥ 80% -10 °C ≥ 75% -20 °C ≥ 70%
Capacity retention (room temp.)	Residual capacity ≥ 85% Recoverable capacity ≥ 90%
	25 °C, 100%SOC, residual and recoverable capacity will be tested after 28 days at 25 °C±2 °C

Storage characteristics	Recoverable capacity ≥ 80% (25°C; relative humidity: 45-75%; 40-50% SOC)
Temperature	Charge: 0 to +45 °C Discharge: -20 to +60 °C
Storage temperature	1 month: -5 to 45 °C (Recommended: -5–35 °C) 3 months: -5 to 35 °C 12 months: -5 to 30 °C
Storage humidity	≤ 75%RH

Environmental Safety Characteristics

Free drop	After standard charge, the cell is to be dropped onto a concrete slab from 1 m height at each anode, cathode 1 time, and cylinder 2 times, for a total of 4 drop tests.	No fire, no explosion
Low pressure	After standard charging, the cell is to be placed in a vacuum oven at 25±5 °C. The inner pressure should decrease to less than 11.6 kPa and keep 6 h.	No fire, no explosion, and no leakage
Crush	After standard charging, the cell is to be crushed along its longitudinal axis parallel to two flat surfaces. The force between the two flat surfaces should be 13.0 kN ±0.78 kN. The test should be performed until the maximum force is achieved. During the test, the cell cannot be short-circuited.	No fire, no explosion
Vibration	After standard charging, the cell should be attached to a vibration table and tested under the following conditions: A sine wave is applied during the vibration test. The testing frequency is from 7 Hz to 200 Hz, then returns to 7 Hz with a total sweeping time of 15 min by the logarithm scanning method. The logarithm scanning method: 7–8 Hz with an acceleration of 9.8 m/s ² , keep amplitude of 0.8 mm to the acceleration of 78.4 m/s ² (50 Hz), and then keep the acceleration of 78.4 m/s ² to 200 Hz frequency. Direction: the cell is to be tested in three mutually-perpendicular directions to the x/y/z-axes for total of 3 h. Each direction should be repeated 12 times.	No fire, no explosion, and no leakage
Temperature cycling	After standard charging, the cell should be placed in a constant temperature oven. The inner temperature of the oven should be tested 10 times.	No fire, no explosion, and no leakage
Impact	After standard charging, the cell should be placed on a flat surface. A 15.8±0.2 mm diameter bar is to be placed across the center of the cell. A 9.1±0.1 kg hammer is to be dropped on the cell from a height of 610 mm±25 mm. Keep 6 h.	No fire and no explosion
Heating (130 °C/30 min)	After standard charging, the cell should be heated in a circulating air oven. The temperature of the oven should be raised to 130±2 °C at a rate of 5±2 °C/min and held for 30 min.	No fire and no explosion
Burning	After standard charging, the cell is to be fixed on a steel mesh and heated with a flame until the following situations occur: 1. explosion; 2. complete combustion; 3. Continuous burning for 30 min.	The components of the cell or the cell as a whole cannot penetrate the aluminum mesh
Acceleration shock	After standard charging, the cell is to be fixed on an impact table, and the test should be conducted under the half-sine acceleration pulse. At the first 3 ms, the minimum average acceleration is 75 gn, the peak acceleration is 150 gn±25gn, and the test time is about 6 ms±1 ms. Every side of the cell should be tested 3 times.	No fire, no explosion and no leakage

Note: The above information is generally descriptive only and is not intended as a guarantee or warranty. Uniross reserves the right to alter or amend the design, model and specification without prior notice.

Safety Considerations

- Stop charging the battery if charging isn't completed within the specified time.
- Don't use an unspecified charger or breach charging requirements. Charging cells under unspecified conditions may lead to overcharging or abnormal chemical reactions that cause heat, smoking, rupture, or fire.
- Don't expose the cell to direct sunlight (or in a car exposed to sunlight) and keep it away from children. Seek immediate medical attention if the cell is swallowed or inhaled.
- Don't expose the cell to extreme hot environments, and don't dispose of it in fire or water. It is dangerous to modify or disassemble the cell, which may cause fire, heating, leakage, or explosion.
- Don't short-circuit cell positive (+) and negative (-) terminals and keep the cell away from metals and other conductive materials. Don't reverse the positive (+) and negative (-) terminals.
- Remove the cell from the device or cell charger, and stop using it immediately once an abnormal situation such as heating, gas generation, discoloration, or deformation occurs.
- Don't weld the cell directly. Excessive heating may deform the cell components such as the gasket, which may lead to swelling, leakage, fire, or explosion.
- Don't use a cell that has been damaged by shipping stress, dropping, short-circuiting, or has an electrolyte smell.

Note: The above information is generally descriptive only and is not intended as a guarantee or warranty. Uniross reserves the right to alter or amend the design, model and specification without prior notice.